



SERVING THE FOOD INDUSTRY SINCE 1951

TURBOVAC HEAVY-DUTY VAC PACK MACHINE 100M³

Item: 45310 Model: M50-LS

PLUG-AND-PLAY
TABLETOP VACUUM
PACKAGING
MACHINES FOR
**CATERING AND
RESTAURANTS**



MAIN FEATURES:

- ☆ **High-quality**
Busch vacuum pump
- ☆ **Deep-drawn**
vacuum chamber
- ☆ **Maintenance friendly**
construction
- ☆ **Cable free**
welding bar construction
- ☆ **Optional:**
Starter kit with consumable
(Teflon tape, welding wire)
- ☆ **Standard 10 Program**
Digital Time Control
- ☆ **Trenn (pre-cut)**
/ 1-2 / Bi-Active seal



Authorized Dealer

TECHNICAL DRAWINGS & DIMENSIONS

*measurements in diagrams are in mm

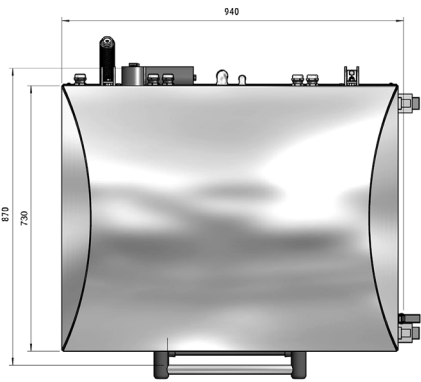
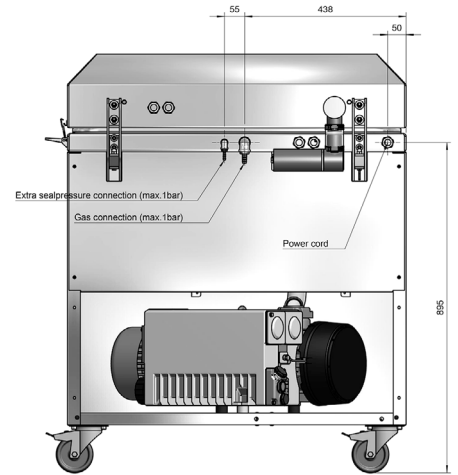
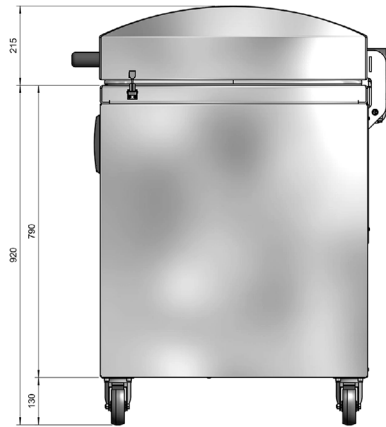

SEAL CONFIGURATIONS

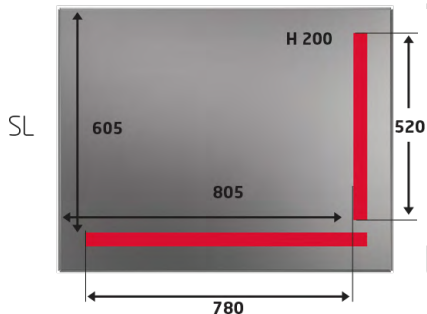

TECHNICAL SPECIFICATIONS

Vacuum Packaging Machine 100m ³	
Item Number	45310
Model	M50-LS
Seal	Double
Seal Length	745 - 805 - 820mm 29.3" - 31.7" - 32.3"
Description	Stainless Steel Cover Flat Working Surface
Voltage	220V/ 60 Hz/ 3
Digital Time Control	10 Programs
Pump Capacity	63 m ³ /h
Net Dimensions	940 x 870 x 1140 mm 37"D x 34.2"W x 44.9"H
Weight	308 kg/ 679 lbs
Optional	
Filler Plates	Yes
Sensor Control	Sensor/ H ₂ O
Soft Air	Soft Air
Seal	Trenn (pre-cut) / 1-2 / Bi-Active
Gas	Gas
Pump Upgrade	100 or 160 m ³

OMCAN INC.

Telephone: 1-800-465-0234

Fax: (905) 607-0234

Email: sales@omcan.com

Website: www.omcan.com



Follow us to keep up to date with the latest news and offers

